

ROM-RI

REVOLUTIONIZE YOUR
END-OF-LINE [PACKAGING]
PERFORMANCE



Operator Cycled or Fully Automatic
Strapping Machine



Standard 3 Heat Sealer



Track Radius 300mm



Up To 15 Bundles Per Minute



Machine Options Available



MOSCA®

EAM MOSCA®

ROM-RI

OPERATOR CYCLED OR FULLY AUTOMATIC STRAPPING MACHINE FOR BUNDLING APPLICATIONS

The ROM-RI features a unique ring shaped strap track that fully retracts into the table. This feature enables product to be conveyed across the tabletop prior to and after completion of the strapping cycle, making it a suitable solution for bundled products such as wood moldings and plastic or aluminum extrusions.

The compact design can be built into most production lines and capable of integration with automated control systems.



TECHNICAL SPECIFICATIONS

Production Rate

Up to 15 bundles per minute

Product Size

5" Min bundle width required. Due to the nature of the curved arch, please consult an EAM-Mosca representative on correct sizing options for your application. Product sizes shown are an estimation only.

Estimated Bundle Size:

2" High, Max Width is 19.5"

4" High, Max Width is 18"

6" High, Max Width is 15.5"

8" High, Max Width is 12"

10" High, Max Width is 5"

Track Size

Inside Track Radius 11.8" (300mm)

Electrical

240v-440v 60 Hz, 0.5 KVA 3 phase

Table

Stainless steel table top

Table Height

Regular: 33" (840mm) - 36" (920mm)

Without Casters: 29" (738mm)

Strapping

Heat sealer runs PP strap from 8-12mm.

Strap Tension

10-100 lbs.

Strap Seal

Heat seal with DC brushless direct drive motor

Machine Shipping Weight

Approx. 540 Lbs.

Casters

Four heavy-duty lockable casters. As an option casters can be removed to adjust table height.

SPECIAL FEATURES

- + Track features unique safety mechanism that detects any obstruction during operation. Once detected the track immediately stops operation and returns to normal mode. Production is able to proceed when clear.
-

OPTIONS

- + Photo Eye (for automatic cycle start)
- + Footswitch
- + Dispenser cover
- + Electrical cabinet can be placed on the left or right side, or externally, separate from machine. External Cabinet includes (16'4"/5m cable)
- + Strap change left or right side
- + Signal exchange for integration into a full automatic line

SCAN
HERE



Want to see
the ROM-RI
in action? Use
the QR code
to learn more.

MACHINE DIMENSIONS

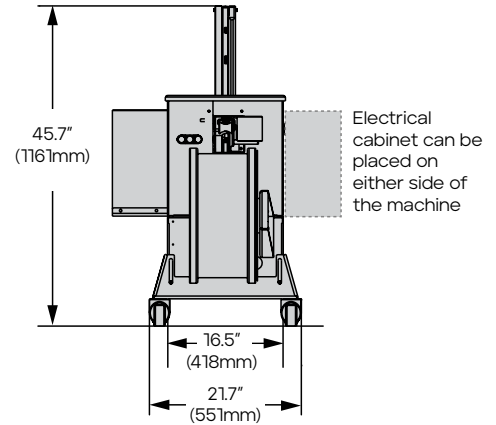
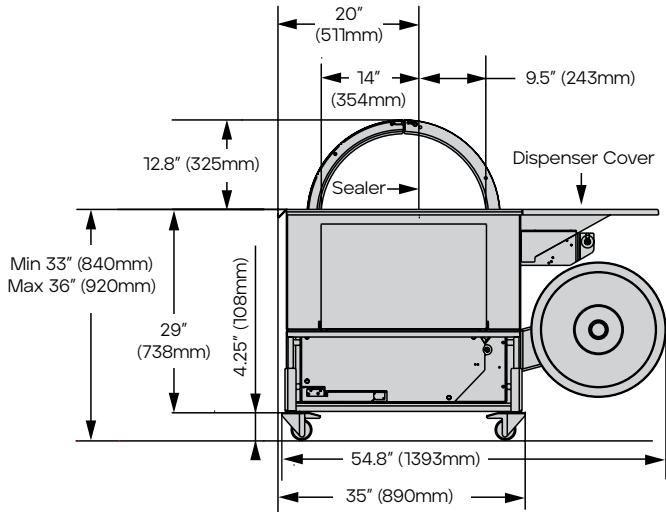

CONTACT US FOR A FREE CONSULTATION TODAY
www.eammosca.com | info@eammosca.com

U.S.A, Latin America & The Caribbean

EAM-Mosca Corporation

675 Jaycee Drive, Hazle Township, PA 18202
Phone: +1 800.456.3420 / +1 570.459.3426
Fax: 570.455.2442

Canada

EAM-Mosca Canada Ltd.

170 William Smith Drive, Whitby, Ontario, L1N 9N3
Phone: +1 800.633.6392 / +1 905.665.8225
Fax: 905.665.8188