

TR-6 SoniXs[®]

Strapping Machine



KEY FEATURES

A

Fully Automatic



Standard 6 Sealer



Up to 1000mm Wide



Up To 40



Optional Pneumatic Press and Backstops

Application: Bundle | Close

The TR-6 SoniXs[®] fully automatic strapping machine is available in two convenient configurations, base and pro for maximum flexibility, and combines high-speed with low-cost and reliability. Leading/trailing strap placement options as standard. Mosca's proprietary SoniXs[®] ultrasonic sealing technology creates a reliable, strong seal with increased cycle life, no warm up required, reduced cleaning and preventive maintenance.

TR-6 SoniXs®

Strapping Machine

PRODUCTION RATE	Up to 40 bundles per minute
TRACK SIZE	Base: 500mm x 400mm, 600mm x 600mm, 800mm x 600mm Pro: 500mm x 600mm, 600mm x 600mm, 800mm x 600mm, 800mm x 800mm, 1000mm x 1000mm
ELECTRICAL	100-600V, 50/60hz, 1 Ph 0.25 KVA
CONTROLS	Base: Push button panel operator interface (upgrade to Pro controls available) Pro: B&R PLC/HMI with advanced controls
AIR REQUIREMENTS	Pneumatic press option: 3 CFM @87 psi
TABLE	Standard: Belt conveyor 3" between center belts Optional: Roller conveyor
TABLE HEIGHT	Standard: 27.6" (700mm) - 34.3" (870mm) With Risers: 34.3" (870mm) - 40.9" (1040mm)
STRAPPING	SoniXs® sealer runs PP strap and select PET strap 5mm, 6mm, 8mm, 9mm, 12mm
STRAP TENSION	Infinitely adjustable up to 60 lbs.
STRAP SEAL	SoniXs® Ultrasonic seal with DC brushless direct drive motor
SEAL LOCATION	Base & Pro: All sizes available in Center seal or Offset
MACHINE SHIPPING WEIGHT	Approx. 900 Lbs.
CASTERS	Four swivel-lock casters. Two stabilizing feet
ADDITIONAL OPTIONS	<ul style="list-style-type: none"> • Photo Eye (for automatic cycle start) • Pneumatic press and/or backstops • Powered belt conveyor • Powered roller conveyor • Multiple entry/exit table lengths for belt conveyor • Light tower • Adjustable side guides • Remote program access (Pro model) • Dual dispenser • Automatic coil change

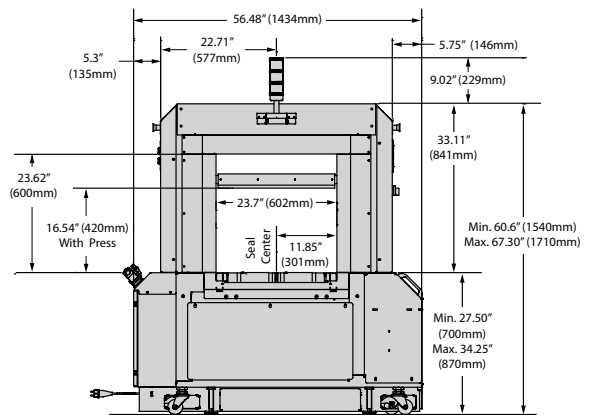
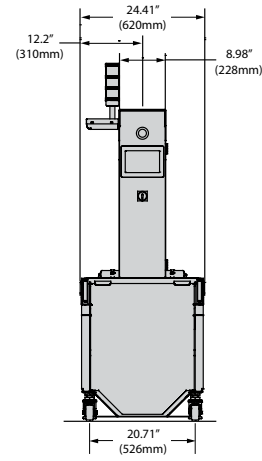

Please visit our website for more information about Mosca's SoniXs® technology.

U.S.A, Latin America and Caribbean:
EAM-Mosca Corporation
 675 Jaycee Drive
 Hazle Township, PA 18202
 800.456.3420
 570.459.3426
 570.455.2442
 info@eammosca.com
 www.eammosca.com

Canada:
EAM-Mosca Canada Ltd.
 170 William Smith Drive
 Whitby, Ontario, L1N 9N3
 800.633.6392
 905.665.8225
 905.665.8188
 info@eammosca.com
 www.eammosca.com