

ROMP-6R- VA SoniXs

REVOLUTIONIZE YOUR
END-OF-LINE [PACKAGING]
PERFORMANCE



Fully Automatic Strapping Machine



Standard 6 SoniXs® Ultrasonic Sealer



Engineered For Cold, Wet Environments



Track Size 600 x 600mm



Up To 40 Bundles Per Minute



ROMP-6R-VA SoniXs

FULLY AUTOMATIC STRAPPING MACHINE FOR CLOSING PRODUCTS IN HARSH WET ENVIRONMENTS

The ROMP-6R-VA SoniXs® is an automatic strapping machine engineered for harsh food processing environments. Built to IP56 protection standards, the robust stainless-steel enclosure provides the best protection available in the market today. An IP (ingress protection) rating classifies the degree of protection against the intrusion of solid objects, dust, accidental contact, and water in electrical enclosures.



The Ultimate Strap Sealing Solution

Mosca's proprietary SoniXs® ultrasonic sealing heads have revolutionized strapping systems offering significant and proven advantages over traditional heat-seal technologies, including cost, maintenance, and longevity across all industries and applications.

Unlike heat seal systems, SoniXs® strap seals are made without the use of high-temperature components, reducing energy costs, improving safety, and generating lower emissions.

A SoniXs® seal is harder to break, and the visible evidence of a break is irreversible. The distinctive impression on Mosca's ultrasonically-sealed strap makes it easy to identify if the packaging has been tampered with. The seal will be distinguishably different if a strap is removed and reapplied.

Key Benefits

- + **INCREASED SEAL STRENGTH**
 - + **COST SAVINGS**
 - + **LASTING DURABILITY**
 - + **CONSISTENT SEALING**
 - + **WORRY-FREE PRODUCT SECUREMENT**
 - + **ENERGY CONSERVATION**
 - + **LOW MAINTENANCE**
 - + **SEALS BOTH PP AND PET**
-

TECHNICAL SPECIFICATIONS

Production Rate

Up to 40 bundles per minute, based on unit size

Track Size

600mm H x 600mm W

Electrical

100V - 600V 50/60 Hz, 0.2 - 0.24 kVA

Air Requirements

No requirement for standard machine
3 CFM @ 87 PSI with press option

Table

Powered roller conveyor

Table Height

Standard: 32.25" - 36.5" (820mm - 925mm)
Low: 28.75" - 32.85" (730mm - 835mm) available upon request

Strapping

SoniXs® sealer runs PP strap from 5-12mm and select PET straps

Strap Tension

Infinitely adjustable up to 60 lbs.

Strap Seal

SoniXs® Ultrasonic seal

Seal Location

Bottom

Machine Shipping Weight

Approx. 760 Lbs. on pallet

Casters

Two swivel-lock casters, and two fixed casters

SPECIAL FEATURES

- + A stainless-steel version of Mosca's SoniXs® ultrasonic sealing head for superior seal performance in cold, wet environments.
- + Corrosion-resistant components and stainless steel enclosure for increased durability and system life.
- + Easy safe Cleaning - IP56 protection ensures the system can be hosed down for cleaning and is protected against high-pressure water jets from any direction.

OPTIONS

- + Control upgrade
- + Pneumatic press
- + Reversible conveyor direction
- + Photo eye and/or remote pedal activation



Want to see the ROMP-6R-VA SoniXs® in action? Use the QR code to learn more.

MACHINE DIMENSIONS

Standard Frame: 32" - 36.5" (820mm - 925mm)

Low Frame: 29" - 33" (730 - 835mm)

**Roller top depth. Belt top depth is 24" (605mm)

Drawing shown with optional pneumatic press

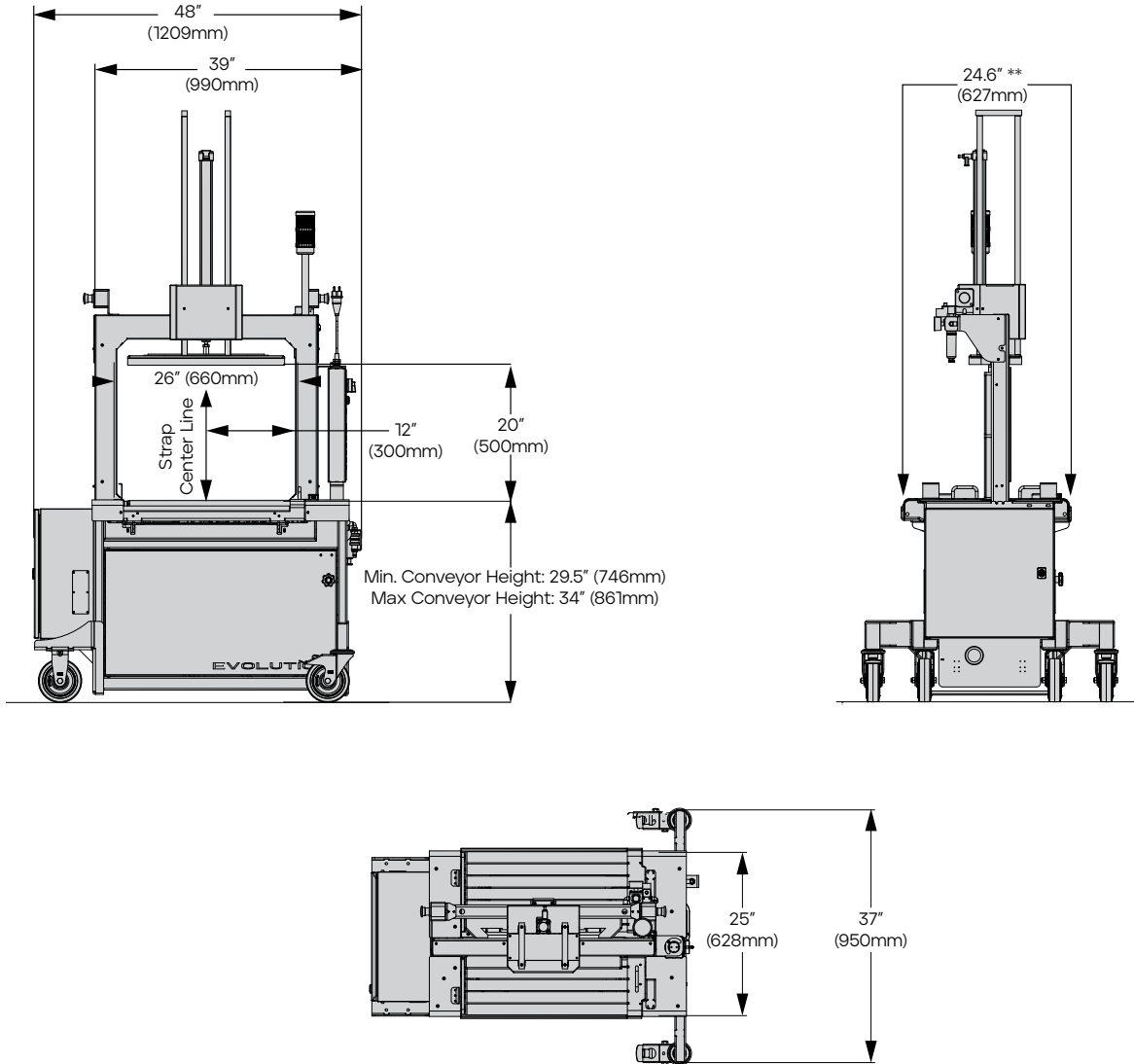

CONTACT US FOR A FREE CONSULTATION TODAY
www.eammosca.com | info@eammosca.com

U.S.A., Latin America & The Caribbean

EAM-Mosca Corporation

675 Jaycee Drive, Hazle Township, PA 18202
Phone: +1 800.456.3420 / +1 570.459.3426
Fax: 570.455.2442

Canada

EAM-Mosca Canada Ltd.

170 William Smith Drive, Whitby, Ontario, L1N 9N3
Phone: +1 800.633.6392 / +1 905.665.8225
Fax: 905.665.8188