

# UCB SoniXs

REVOLUTIONIZE YOUR  
END-OF-LINE [PACKAGING]  
PERFORMANCE



Fully Automatic Squaring Bundler



Standard 6 SoniXs® Ultrasonic Sealer



Track Size Up To 1650mm Wide



Up To 32 Bundles Per Minute



Machine Options Available

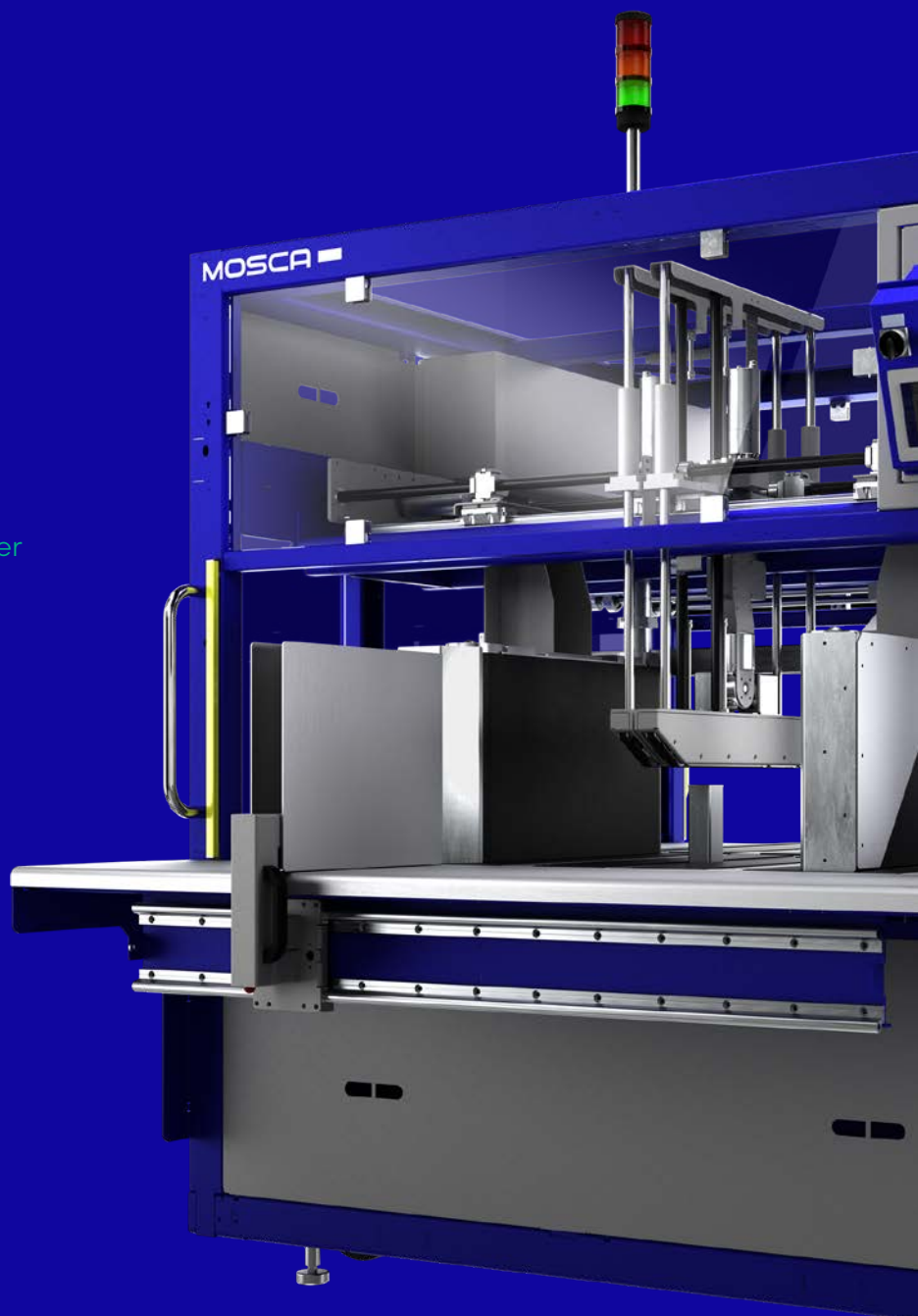

# UCB SoniXs

## FULLY AUTOMATIC FIVE-SIDED SQUARING BUNDLER

The UCB SoniXs® is a high-performing, fully automatic bundler for corrugated products streaming from specialty folder gluers. Its five-sided squaring system intuitively adjusts to the size of the bundle, ensuring compact, square bundles every time. Included is an adjustable speed conveyor. This machine is designed specifically to handle high gloss products that require gentle product handling to prevent damage and to keep the bundle together. It is equipped with a conveying belt under, along the sides, and along the top of the product to keep the bundle intact and prevent bottom or top sheets going astray.



## The Ultimate Strap Sealing Solution

Mosca's proprietary SoniXs® ultrasonic sealing heads have revolutionized strapping systems offering significant and proven advantages over traditional heat-seal technologies, including cost, maintenance, and longevity across all industries and applications.

Unlike heat seal systems, SoniXs® strap seals are made without the use of high-temperature components, reducing energy costs, improving safety, and generating lower emissions.

A SoniXs® seal is harder to break, and the visible evidence of a break is irreversible. The distinctive impression on Mosca's ultrasonically-sealed strap makes it easy to identify if the packaging has been tampered with. The seal will be distinguishably different if a strap is removed and reapplied.

---

## Key Benefits

- + **INCREASED SEAL STRENGTH**
  - + **COST SAVINGS**
  - + **LASTING DURABILITY**
  - + **CONSISTENT SEALING**
  - + **WORRY-FREE PRODUCT SECUREMENT**
  - + **ENERGY CONSERVATION**
  - + **LOW MAINTENANCE**
  - + **SEALS BOTH PP AND PET**
-

---

## TECHNICAL SPECIFICATIONS

---

### Production Rate

Up to 32 single & 20 double strapped bundles per minute

---

### Product Size\*

Product min: 6" L, 6" W, 0.8" H (150mm L, 150mm W, 20mm H)  
Product max: 55" L, 47"/63" W, 16" H (1,400mm L, 1,200/1,600 W, 400mm H)

\*Without optional backside product alignment device

---

### Track Size

1250mm and 1650mm (49" and 65")

---

### Electrical

110V - 220V 50/60 Hz, 0.5 kVA

---

### Table

Stainless steel table top with belts

---

### Table Height

31.5" - 39.5" (800mm - 1000mm)

---

### Strapping

SoniXs® ultrasonic seal runs PP strap 5mm, 6mm, 8mm, 9mm, 12mm or PET strap 9mm or 11mm

---

### Strap Tension

Adjustable from 10 - 60 Lbs.

---

### Strap Seal

SoniXs® ultrasonic seal

---

### Seal Location

Center

---

### Machine Shipping Weight

Approx. 4400 Lbs. without pallet

---

### Casters

Heavy-duty lockable casters

---

## OPTIONS

---

- + Fully automatic strap coil change with dual coil dispenser
- + 3-part signal light with LED technology
- + Package alignment backside
- + Second package stop for second strapping
- + Low strap detection with signal in the control panel
- + Full network communication inclusive RMI
- + Floor rails
- + Air table
- + Infeed table with package stop. Left or right configuration available

SCAN  
HERE



Want to see the  
UCB SoniXs®  
in action? Use  
the QR code  
to learn more.

---

# MACHINE DIMENSIONS

---

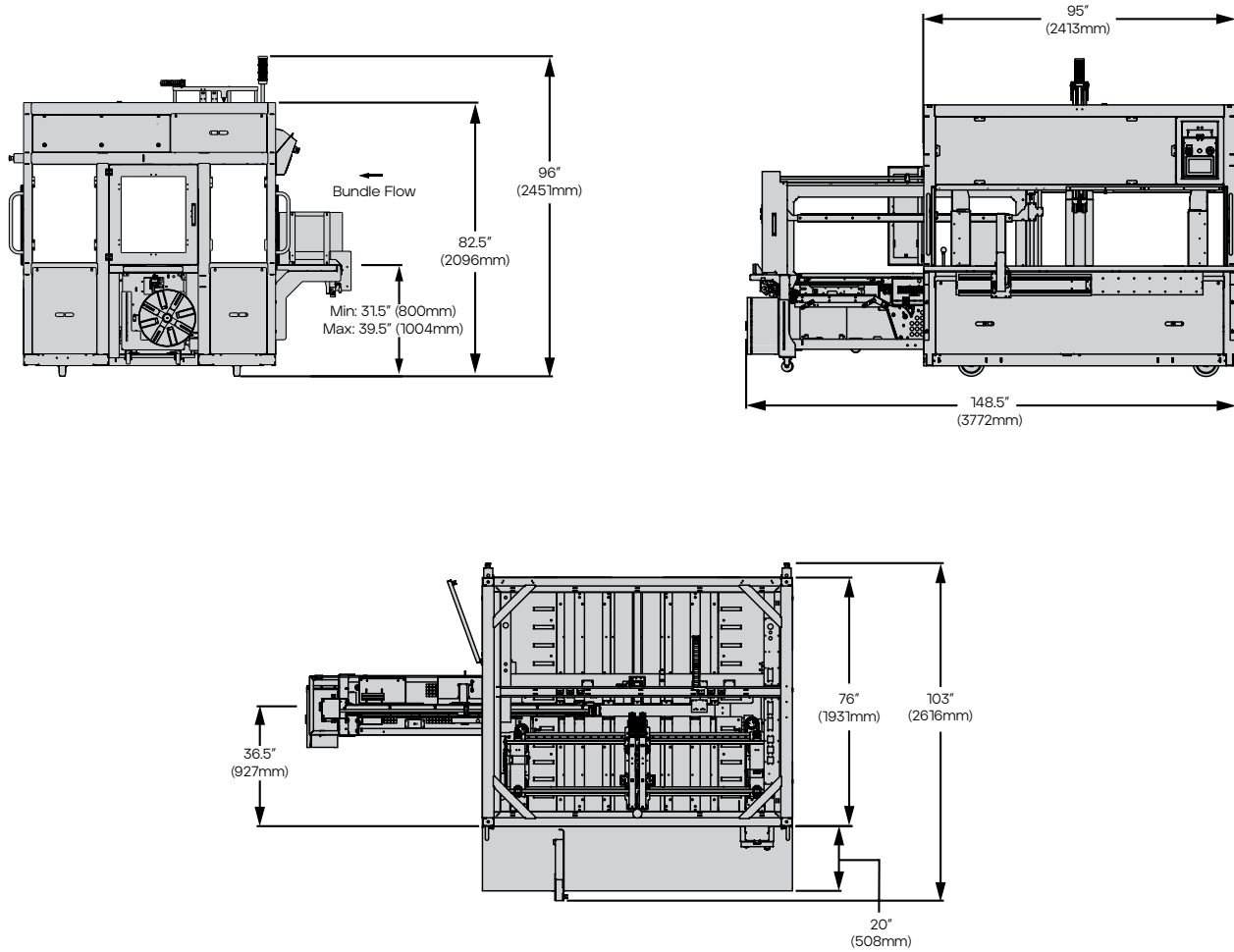

---

CONTACT US FOR A FREE CONSULTATION TODAY  
[www.eammosca.com](http://www.eammosca.com) | [info@eammosca.com](mailto:info@eammosca.com)

## U.S.A., Latin America & The Caribbean

### EAM-Mosca Corporation

675 Jaycee Drive, Hazle Township, PA 18202  
Phone: 800.456.3420 / 570.459.3426  
Fax: 570.455.2442

## Canada

### EAM-Mosca Canada Ltd.

170 William Smith Drive, Whitby, Ontario, L1N 9N3  
Phone: 800.633.6392 / 905.665.8225  
Fax: 905.665.8188