

# TRC-6 SQ4 SoniXs Tandem

REVOLUTIONIZE YOUR  
END-OF-LINE [PACKAGING]  
PERFORMANCE



Fully Automatic  
Squaring System



Standard 6 SoniXs<sup>®</sup>  
Ultrasonic Sealer



Track Size Up To 1650mm Wide



Up To 36 Bundles Per Minute



Machine Options Available



# TRC-6 SQ4 SoniXs Tandem

## FULLY AUTOMATIC TANDEM SQUARING AND STRAPPING SYSTEM

The TRC6-SQ4 SoniXs® Tandem is an integrated two-stage high-speed bundling solution. Its two-zone entry/pacing conveyors reduce transport time for small bundles to help meet the throughput and integration requirements of high-speed flexo lines. When used behind a box slitter, small bundles are automatically separated to increase throughput.

Mosca's SoniXs® Evolution generation features a unified strap path for improved feed reliability and toolless track disassembly for quick maintenance and cleaning. Electrically driven backstops and side conditioners provide the bundle squaring capability for consistently uniform loads.



## The Ultimate Strap Sealing Solution

Mosca's proprietary SoniXs® ultrasonic sealing heads have revolutionized strapping systems offering significant and proven advantages over traditional heat-seal technologies, including cost, maintenance, and longevity across all industries and applications.

Unlike heat seal systems, SoniXs® strap seals are made without the use of high-temperature components, reducing energy costs, improving safety, and generating lower emissions.

A SoniXs® seal is harder to break, and the visible evidence of a break is irreversible. The distinctive impression on Mosca's ultrasonically-sealed strap makes it easy to identify if the packaging has been tampered with. The seal will be distinguishably different if a strap is removed and reapplied.

---

## Key Benefits

- + **INCREASED SEAL STRENGTH**
  - + **COST SAVINGS**
  - + **LASTING DURABILITY**
  - + **CONSISTENT SEALING**
  - + **WORRY-FREE PRODUCT SECUREMENT**
  - + **ENERGY CONSERVATION**
  - + **LOW MAINTENANCE**
  - + **SEALS BOTH PP AND PET**
-

---

## TECHNICAL SPECIFICATIONS

---

### Production Rate

Up to 36 single and 24 double strapped bundles per minute

---

### Product Size

Smallest bundle:

Standard: 8" W x 11" L (203mm W x 280mm L)

Small bundle option: 7" x 7" (178mm W x 178mm L)

Largest bundle:

With squaring: 56" (1423mm) W

Without squaring engaged: Up to 63" (1600mm) W

---

### Track Size

1650mm x 600mm (65" x 23 1/2")

---

### Electrical

200 - 575V 50/60 Hz, 1.5 KVA, 3 Ph.

---

### Air Requirements

4 CFM @ 87 PSI

---

### Conveyor

Extruded splined roller conveyor. Flow direction right to left

---

### Conveyor Speed

Variable 30 - 180 FPM

---

---

## OPTIONS

---

- + Small bundle option
- + Dual dispenser
- + Automatic coil changer
- + Light tower
- + 30" Substitute conveyor
- + Pacer conveyors
  - Multiple sizes available
  - Belt over roller option for smoother transfer of small and unstable bundles.
- + Floor troughs
- + Under table lighting
- + Automatic blow out
- + Bundle size data transfer via external input
- + Reverse flow (left to right)
- + Automatic lateral positioning
- + Remote Support
- + Additional protective guarding
- + Custom paint color (RAL color chart)

More options available

### Conveyor Height

Outriggers required: 25" - 30" (648mm - 775mm)

Standard: 30" - 39" (775mm - 1003mm)

Riser required: 39" - 47" (1003mm - 1194mm)

Risers + outriggers required: 47" - 54" (1194mm - 1371mm)

Risers + outriggers required: 54" - 61" (1371mm - 1562mm)

---

### Strapping

Standard: PP - 5mm (other widths available)

---

### Strap Tension

Infinitely adjustable from 10 - 60 Lbs.

---

### Strap Seal

SoniXs® ultrasonic seal

---

### Seal Location

Bottom center seal

---

### Machine Shipping Weight

Approx. 1650 Lbs. per machine

---

### Casters

Four heavy-duty swivel-lock casters

---

SCAN  
HERE



Want to see  
the TRC-6 SQ4  
SoniXs® Tandem  
in action? Use  
the QR code  
to learn more.

# MACHINE DIMENSIONS

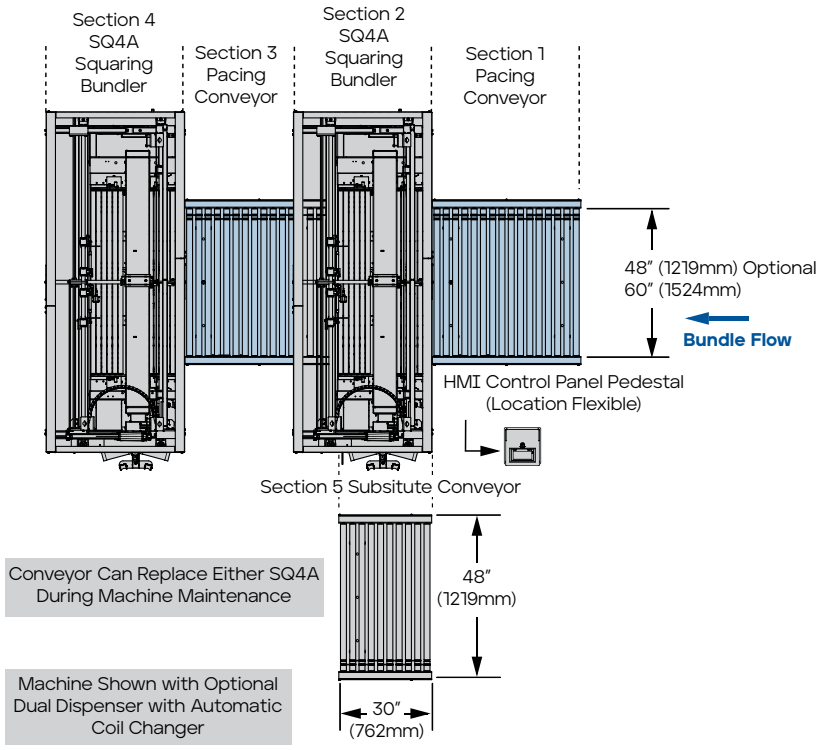
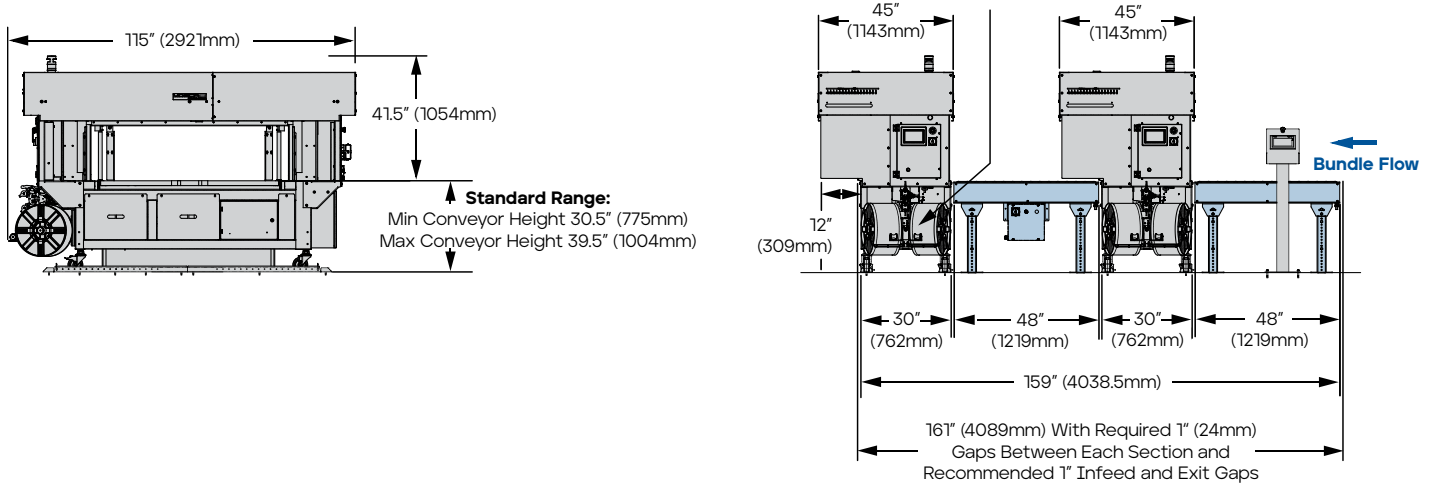

CONTACT US FOR A FREE CONSULTATION TODAY  
[www.eamosca.com](http://www.eamosca.com) | [info@eamosca.com](mailto:info@eamosca.com)

**U.S.A., Latin America & The Caribbean**

**EAM-Mosca Corporation**  
 675 Jaycee Drive, Hazle Township, PA 18202  
 Phone: 800.456.3420 / 570.459.3426  
 Fax: 570.455.2442

**Canada**

**EAM-Mosca Canada Ltd.**  
 170 William Smith Drive, Whitby, Ontario, L1N 9N3  
 Phone: 800.633.6392 / 905.665.8225  
 Fax: 905.665.8188