

USI-2 SoniXs

REVOLUTIONIZE YOUR
END-OF-LINE PACKAGING
PERFORMANCE



Fully Automatic Load Securing
Strapping Machine With Indexing Head



Heavy-duty SoniXs® Ultrasonic
Unitizer Sealer



Track Size Up to 3000mm W x 2800mm H



Production Rate Dependent On
Product Handling Requirements

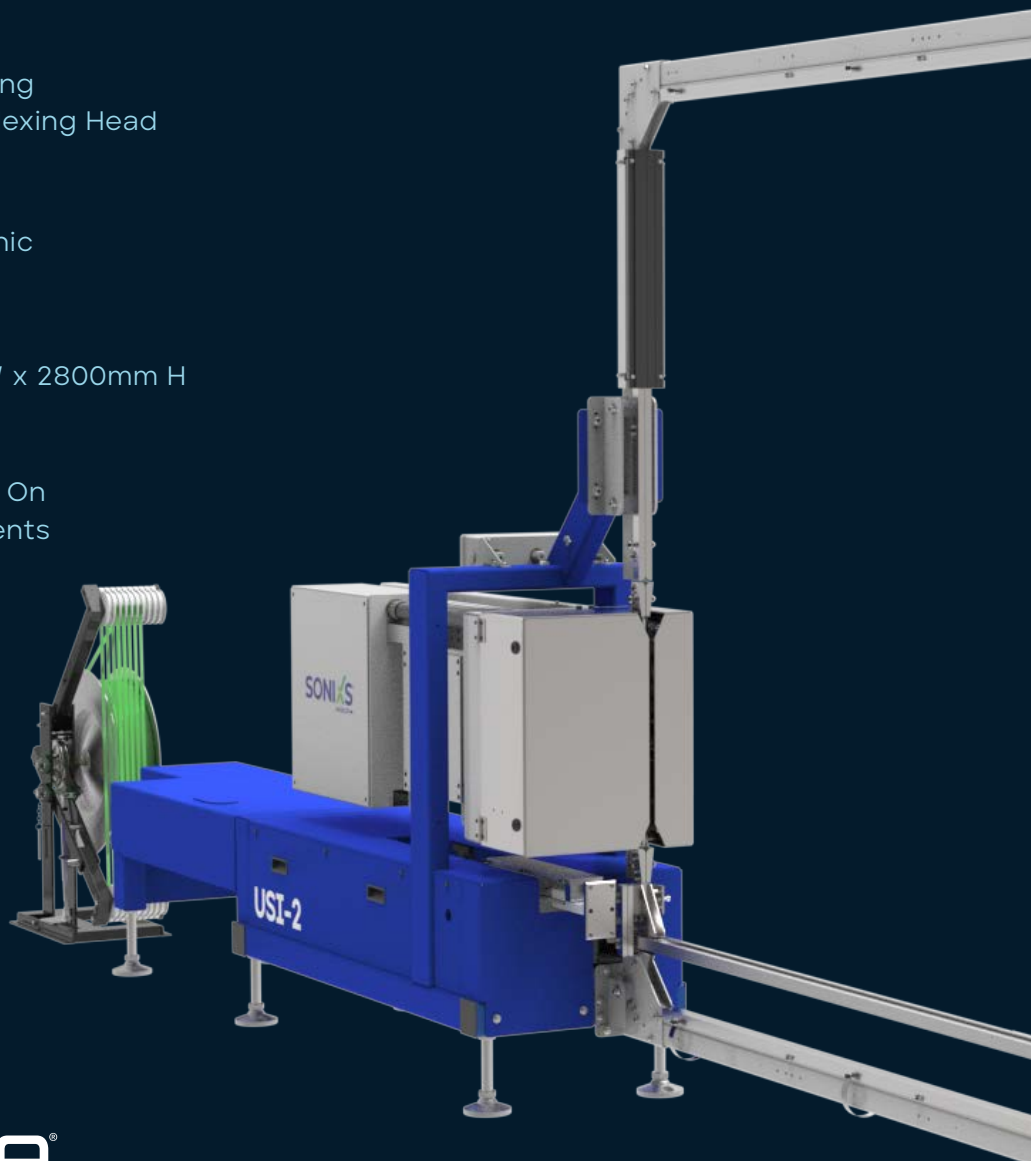

USI-2 SoniXs

FULLY AUTOMATIC STRAPPING MACHINE FOR LOAD SECURING

The USI-2 SoniXs® is a versatile, high-tension side seal strapping machine designed to strap various large packages and shipping units including rigid packaging and beverage containers.

Features include a smaller footprint to make moving around more convenient in compact spaces, and a heavy-duty strapping head that indexes up to 16 inches to meet the side of the load, for increased strap tension and greater seal performance.



The Ultimate Strap Sealing Solution

Mosca's proprietary SoniXs® ultrasonic sealing heads have revolutionized strapping systems offering significant and proven advantages over traditional heat-seal technologies, including cost, maintenance, and longevity across all industries and applications.

Unlike heat seal systems, SoniXs® strap seals are made without the use of high-temperature components, reducing energy costs, improving safety, and generating lower emissions.

A SoniXs® seal is harder to break, and the visible evidence of a break is irreversible. The distinctive impression on Mosca's ultrasonically-sealed strap makes it easy to identify if the packaging has been tampered with. The seal will be distinguishably different if a strap is removed and reapplied.

Key Benefits

- + **INCREASED SEAL STRENGTH**
 - + **COST SAVINGS**
 - + **LASTING DURABILITY**
 - + **CONSISTENT SEALING**
 - + **WORRY-FREE PRODUCT SECUREMENT**
 - + **ENERGY CONSERVATION**
 - + **LOW MAINTENANCE**
 - + **SEALS BOTH PP AND PET**
-

TECHNICAL SPECIFICATIONS

Production Rate

Dependent on product handling requirements

Product Size

Min product height: 500mm (19.7")
For lance only, and lower track options

Pass-Through Size

Pallet Lance and Lower Track, and Pallet Lance
Only Configurations:

1200mm - 2100mm (47" - 82") Width x
1550mm - 2800mm (61" - 110") Height

Lower Track Only Configuration:

1200mm - 3000mm (47" - 118") Width x
1550mm - 2800mm (61" - 110") Height

Pallet Lance: Requires no conveyor gap

Lower Track: Requires 4" conveyor gap

Custom sizes may be available on request.

Electrical

120-575V, 50/60 hz, 3 ph

Controls

PLC with 7" touchscreen HMI

Standard: Allen Bradley. Optional: Siemens

Conveyor Height

191mm - 1016mm (7.5" - 40")

Strapping

SoniXs® sealer runs 9mm-12mm PP or PET strap

Strap Tension

Infinitely adjustable up to 204kg (450 Lbs.)

Strap Seal

SoniXs® ultrasonic seal, with DC brushless direct drive motor

Seal Location

Side seal with indexing head up to 16" to meet the side of
the load

Machine Shipping Weight

Approx. 544.3kg (1200 lbs.)

OPTIONS

- + Pallet lance and/or lower track (lance only deploys when a pallet void is detected)
 - + 3 Tier light tower with upgraded user-adjustable integrated audible alarm
 - + Spare sealer head assembly
 - + Electrical enclosure safety lock
 - + "Floating" sealer head carriage assembly for optimal strap tension equalization.
 - + Electric or pneumatic load stabilizer (compatible with standard conveyor heights only)
-

SPECIAL FEATURES

- + "Quick Change" sealer head assembly.
 - + Machine power disconnect switch.
 - + Configurable pallet/load sensor.
-

INTEGRATION CAPIBILITIES

At EAM-Mosca, we support a wide range of applications. We can integrate our products into most situations with equipment ranging from the simplest bundlers to fully automated pallet strapping, unitizing, and stretch wrapping systems. Our capabilities include designing integrated controls when appropriate and supporting broader-based system integrators as needed. We aim to provide our customers with productive and economically justifiable solutions for their end-of-line packaging needs.

SCAN
HERE



Want to see the
USI-2 SoniXs
in action? Use
the QR code
to learn more.

MACHINE DIMENSIONS

		Available Arch Sizes & Styles						
		Width						
		1200mm (47")	1500mm (59")	1800mm (71")	2100mm (83")	2400mm (94")	2700mm (106")	3000mm (118")
Height	2800mm (110")							
	2550mm (100")							
	2300mm (90")							
	2050mm (81")							
	1800mm (71")							
1550mm (61")								

■ Available as Track Only, Lance Only and Lance with Track
■ Available as Track Only Configuration
 (Custom sizes may be available)

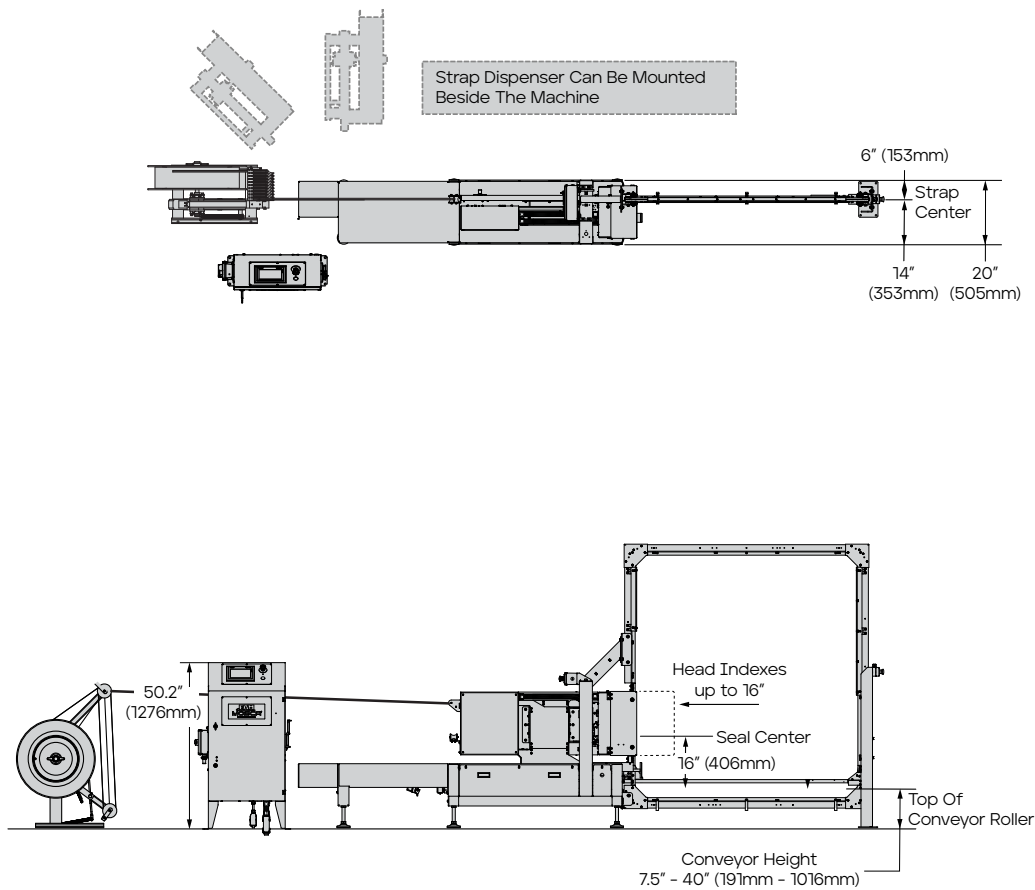

CONTACT US FOR A FREE CONSULTATION TODAY
www.eamosca.com | info@eammosca.com

U.S.A, Latin America & The Caribbean

EAM-Mosca Corporation
 675 Jaycee Drive, Hazle Township, PA 18202
 Phone: +1 800.456.3420 / +1 570.459.3426
 Fax: 570.455.2442

Canada

EAM-Mosca Canada Ltd.
 170 William Smith Drive, Whitby, Ontario, L1N 9N3
 Phone: +1 800.633.6392 / +1 905.665.8225
 Fax: 905.665.8188