

ROMP-6B SoniXs

REVOLUTIONIZE YOUR
END-OF-LINE [PACKAGING]
PERFORMANCE



Fully Automatic Strapping Machine



Standard 6 SoniXs® Ultrasonic Sealer



Track Size Up To 1000mm Wide



Up To 40 Bundles Per Minute



Machine Options Available



ROMP-6B SoniXs

FULLY AUTOMATIC STRAPPING MACHINE FOR CLOSING & SECURING APPLICATIONS

The ROMP-6B SoniXs® fully automatic machine combines high-speed with low-cost and reliability for a variety of applications including totes and boxes. Features include a powered belt conveyor and multiple track sizes.



The Ultimate Strap Sealing Solution

Mosca's proprietary SoniXs® ultrasonic sealing heads have revolutionized strapping systems offering significant and proven advantages over traditional heat-seal technologies, including cost, maintenance, and longevity across all industries and applications.

Unlike heat seal systems, SoniXs® strap seals are made without the use of high-temperature components, reducing energy costs, improving safety, and generating lower emissions.

A SoniXs® seal is harder to break, and the visible evidence of a break is irreversible. The distinctive impression on Mosca's ultrasonically-sealed strap makes it easy to identify if the packaging has been tampered with. The seal will be distinguishably different if a strap is removed and reapplied.

Key Benefits

- + **INCREASED SEAL STRENGTH**
 - + **COST SAVINGS**
 - + **LASTING DURABILITY**
 - + **CONSISTENT SEALING**
 - + **WORRY-FREE PRODUCT SECUREMENT**
 - + **ENERGY CONSERVATION**
 - + **LOW MAINTENANCE**
 - + **SEALS BOTH PP AND PET**
-

TECHNICAL SPECIFICATIONS

Production Rate

Up to 40 bundles per minute

Track Size

600mm x 600mm, 800mm x 600mm, 1000mm x 800mm

Electrical

100V - 600V, 50/60 Hz, 0.2 - 0.24 kVA

Air Requirements

Pneumatic press option: 3 CFM @87 psi

Conveyor

Powered belt Conveyor (Max table weight 60Lbs/27.2 Kg)

Table Height

Standard: 32.25"-36.5" (820mm-925mm)

Low: 28.75"-32.85" (730-835mm)

Strapping

SoniXs® sealer runs PP strap from 5-12mm and select PET straps. Optional heat sealer runs PP strap from 5-12mm.

Strap Tension

Infinitely adjustable up to 60 lbs.

Strap Seal

SoniXs® Ultrasonic seal with DC brushless direct drive motor

Seal Location

600mm x 600mm center seal. Other sizes offset 12" from arch corner, control panel side

Machine Shipping Weight

Approx. 675 Lbs.

Casters

Two swivel-lock casters, Two fixed casters

OPTIONS

+ Pneumatic press

INTEGRATION CAPIBILITIES

At EAM-Mosca, we support a wide range of applications. We can integrate our products into most situations with equipment ranging from the simplest bundlers to fully automated pallet strapping, unitizing, and stretch wrapping systems. Our capabilities include designing integrated controls when appropriate and supporting broader-based system integrators as needed. We aim to provide our customers with productive and economically justifiable solutions for their end-of-line packaging needs.

SCAN
HERE



Want to see the
ROMP-6B SoniXs
in action? Use
the QR code
to learn more.



MACHINE DIMENSIONS

		A	B		C	D	E	F	G		H	
TRACK SIZE (W x H)		Pneumatic Press							Standard	Low Caster	Standard	Low Caster
		Without	With									
600 x 600	Inches	23.62	23.62	19.69	37.4	46.06	58.66	41.14	32.5-36.5	28.8-32.9	59.5-63.6	55.9-60.0
	mm	600	600	500	950	1170	1490	1045	820-925	730-835	1510-1615	1420-1525
800 x 600	Inches	31.5	23.62	19.69	45.28	54	66.6	49	32.5-36.5	28.8-32.9	59.5-63.6	55.9-60.0
	mm	800	600	500	1150	1370	1690	1245	820-925	730-835	1510-1615	1420-1525
1000 x 800	Inches	39.37	31.5	27.6	53.15	61.8	74.4	56.9	32.5-36.5	28.8-32.9	67.5-71.5	63.8-68.0
	mm	1000	800	700	1350	1570	1890	1445	820-925	730-835	1710-1815	1620-1725

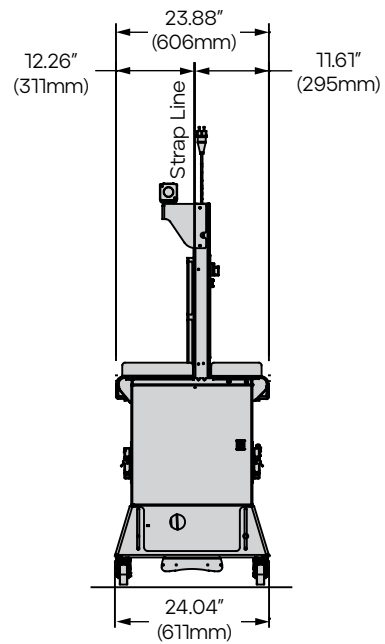
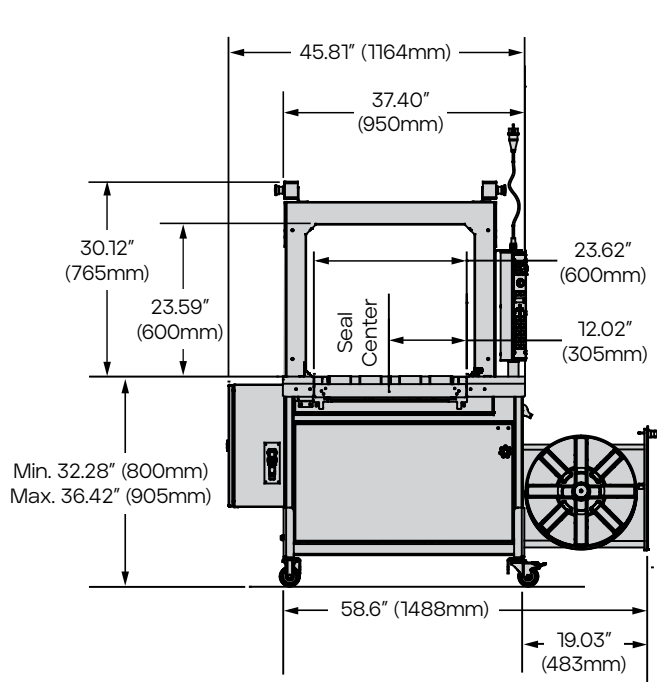

CONTACT US FOR A FREE CONSULTATION TODAY
www.eammosca.com | info@eammosca.com

U.S.A, Latin America & The Caribbean

EAM-Mosca Corporation

675 Jaycee Drive, Hazle Township, PA 18202
 Phone: +1 800.456.3420 / +1 570.459.3426
 Fax: 570.455.2442

Canada

EAM-Mosca Canada Ltd.

170 William Smith Drive, Whitby, Ontario, L1N 9N3
 Phone: +1 800.633.6392 / +1 905.665.8225
 Fax: 905.665.8188