

ROMS-6 SoniXs

REVOLUTIONIZE YOUR
END-OF-LINE [PACKAGING]
PERFORMANCE



Operator Cycled or Fully
Automatic Strapping Machine



Standard 6 SoniXs®
Ultrasonic Sealer



Track Size Up To 1650mm Wide



Up To 58 Bundles Per Minute



Machine Options Available



ROMS-6 SoniXs

FULLY AUTOMATIC SIDE SEALING STRAPPING MACHINE FOR BUNDLING, CLOSING & SECURING APPLICATIONS

The versatility of the ROMS-6 SoniXs® design makes it an excellent choice for a wide variety of applications, from protective packaging and furniture to door and window products and more. Its unique side seal design keeps the strap track free from falling debris that can affect machine performance.



The Ultimate Strap Sealing Solution

Mosca's proprietary SoniXs® ultrasonic sealing heads have revolutionized strapping systems offering significant and proven advantages over traditional heat-seal technologies, including cost, maintenance, and longevity across all industries and applications.

Unlike heat seal systems, SoniXs® strap seals are made without the use of high-temperature components, reducing energy costs, improving safety, and generating lower emissions.

A SoniXs® seal is harder to break, and the visible evidence of a break is irreversible. The distinctive impression on Mosca's ultrasonically-sealed strap makes it easy to identify if the packaging has been tampered with. The seal will be distinguishably different if a strap is removed and reapplied.

Key Benefits

- + **INCREASED SEAL STRENGTH**
 - + **COST SAVINGS**
 - + **LASTING DURABILITY**
 - + **CONSISTENT SEALING**
 - + **WORRY-FREE PRODUCT SECUREMENT**
 - + **ENERGY CONSERVATION**
 - + **LOW MAINTENANCE**
 - + **SEALS BOTH PP AND PET**
-

TECHNICAL SPECIFICATIONS

Production Rate

Up to 58 bundles per minute

Track Size

See chart on the back of the brochure

Electrical

200-575v 3pH, 50/60 hz, 5.3 KVA

Table Height

Accommodates conveyor heights as low as 12" (304mm)

Strapping

SoniXs® sealer runs PP strap from 5-12mm and select PET straps. Optional heat sealer runs PP strap from 5-12mm.

Strap Tension

Infinitely adjustable up to 80 lbs. (36 kg)

Strap Seal

SoniXs® Ultrasonic seal with DC brushless direct drive motor

Machine Shipping Weight

Approx. 800 Lbs. (363 Kg)

Casters

Four swivel-lock casters



SCAN
HERE

Want to see the
ROMS-6 SoniXs
in action? Use
the QR code
to learn more.

OPTIONS

- + Dual dispenser (with manual or automatic changeover)
- + Pneumatic side pusher (only available with single press and up to 650mm x 600mm)
- + Double pneumatic press (available up to 600mm track height)
- + Narrow Sealer (available with 650mm x 600mm, heat seal only. Accommodates small bundles. Min size 4" h x 2" w)
- + Trouble light and low strap indicator
- + Roller conveyor two middle gravity roller to support loads
- + Signal exchange/interface (for integration in automated lines)
- + Footswitch



MACHINE DIMENSIONS

MACHINE ARCH SIZE (W x H)		A	B	C	D	E	F
650 x 600	Inches	25	24.8	32.3	32.3	60	Outrigger Catsers 8.2" - 15.7" (210mm-400mm) Standard 12.2" - 22" (310mm-560mm) Caster + Frame 1 14.2" - 24" (360mm-610mm) Caster + Frame 2 18.1" - 27.9" (460mm-710mm) Caster + Frame 3 22" - 31.9" (560mm-810mm) Caster + Frame 4 26" - 35.8" (660mm-910mm)
	mm	635	630	820	820	1525	
900 x 600	Inches	34.8	24.8	32.3	32.3	69.9	
	mm	885	630	820	820	1775	
900 x 1400	Inches	35.4	56.3	63.8	32.3	71	
	mm	900	1430	1620	820	1805	
900 x 1800	Inches	35.4	72	79.5	44.3	83	
	mm	900	1830	2020	1125	2110	
1300 x 600	Inches	51.2	24.8	32.3	44.3	98.8	
	mm	1300	630	820	1125	2510	
1300 x 1400	Inches	51.2	56.3	63.8	44.3	98.8	
	mm	1300	1430	1620	1125	2510	
1300 x 1800	Inches	51	72	79.5	44.3	98.8	
	mm	1300	1830	2020	1125	2510	
1300 x 2200	Inches	51	87.8	95.3	44.3	98.8	
	mm	1300	2230	2420	1125	2510	
1650 x 600	Inches	65	25	32	44.3	112.6	
	mm	1650	630	820	1125	2860	
1650 x 1400	Inches	65	56.3	63.8	44.3	112.6	
	mm	1650	1430	1620	1125	2860	
1650 x 1800	Inches	65	72	79.5	44.3	112.6	
	mm	1650	1830	2020	1125	2860	

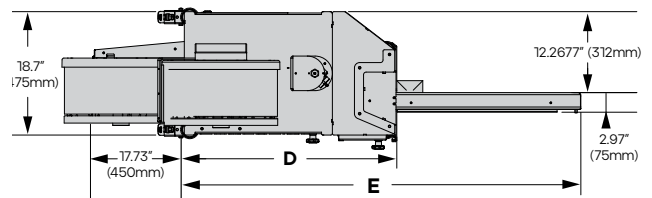
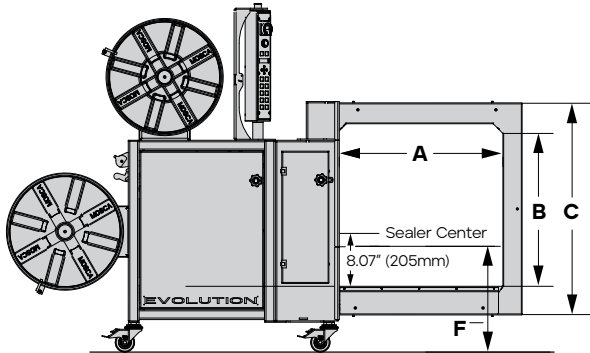

CONTACT US FOR A FREE CONSULTATION TODAY
www.eammosca.com | info@eammosca.com

U.S.A, Latin America & The Caribbean

EAM-Mosca Corporation

675 Jaycee Drive, Hazle Township, PA 18202
 Phone: +1 800.456.3420 / +1 570.459.3426
 Fax: 570.455.2442

Canada

EAM-Mosca Canada Ltd.

170 William Smith Drive, Whitby, Ontario, L1N 9N3
 Phone: +1 800.633.6392 / +1 905.665.8225
 Fax: 905.665.8188